

## BT300 VFD NEMA Type 3R Drive and Bypass

---

### Description

The NEMA Type 3R Bypasses are companion packages for the family of BT300 Variable Frequency Drives (VFDs).

Enclosures with this rating provide a degree of protection to personnel against access to hazardous parts; a degree of protection to the equipment inside the enclosure to keep out solid foreign objects (falling dirt), and water (rain, sleet, snow); and are undamaged by ice forming on the enclosure.

A heater is supplied in the cabinet to protect against condensation and is rated to 104°F (40°C).

The BT300 Type 3R is designed specifically for HVAC applications and supports a variety of digital and analog I/O. It provides built-in features to control pumps and fans.

For information on the family of BT300 VFDs, see the *BT300 HVAC Drives Technical Specification Sheet* (149-711).



### Features

#### Bypass Power

- 3-Contactor: Input, Output and Bypass
  - Overload protection in bypass mode
  - Step-down transformer with primary and secondary fusing
  - Contactors electrically and mechanically interlocked.
  - Drive test function
  - Complete electrical isolation of drive

#### Input Device

- Fused disconnect
- All doors are interlocked and can be padlocked.

#### Reactor Options

- Line reactor supplied separately.
- Load reactor (in NEMA Type 3R enclosure) supplied separately.

#### Bypass Control

##### Enable Input

Generally used for safety tie-ins; the motor will not operate in drive or bypass when open.

##### Common Remote Start/Stop

Can be used in both drive and bypass mode.

##### Essential Services Mode

- Typically used for smoke purge; the motor goes to bypass regardless of the selected mode.
- No call to stop will have an effect, including open safety or stop commands.
- Only turning the power off or opening this contact will stop the motor.

#### Bypass – Door-Mounted Control Devices

- Drive-Off-Bypass selector
- Bypass pilot light
- Drive Test On-Off selector

## Product Numbers

<b>Your Product Number:</b>																				
<b>Example Product Number:</b>		V	B	A	3	4	0	.	F	3	3	0	X	B	T	3	0	0		
<b>Model</b>	VB VFD																			
<b>Series</b>	A	Factory Designation																		
<b>Voltage</b>	1	208/240 V																		
	3	380 to 480 V																		
<b>HP rating</b>	1.0, 1.5, 2.0, 3.0, 4.0, 5.0, 7.5, 10, 15, 20, 25, 30, 40, 50, 60, 75, 100, 125 [See Note 1 for these selections]																			
<b>Disconnect</b>	F	Fused Disconnect																		
<b>NEMA rating</b>	3	NEMA Type 3R																		
<b>Contactor</b>	0	None (Drive only)																		
	3	Contactor Bypass (Input, Output, Bypass)																		
<b>Reactor</b>	[See Note 2]																			
	0	None																		
<b>Filter</b>	X	Factory Required Designator																		
<b>Options</b>	BT300	BT300 Drive																		

**Notes:**

1. Available only with Voltage Codes 3
2. Order as a separate item for input line reactors  
 If a load reactor is required, a separate enclosed reactor is required.

**Example Shown:**

VBA340.F330XBT300 =  
 VBA Conventional Bypass, 480V, 40 HP, fused disconnect,  
 NEMA Type 3R, 3 contactors, no reactor, BT300 Drive.

**Table 1. NEMA Type 3R Bypass Specifications.**

NEMA Type 3R Bypass Specification	Description
Input Voltage (3-phase)	208/240V, 3 AC ±10% 1 HP to 60 HP
	480V, 3 AC ±10% 1 HP to 125 HP
Temperature	Operating: 14°F to 104°F (–10°C to 40°C), may require de-rating to 122°F (50°C)
	Storage: –40°F to 158°F (–40°C to 70°C)
Humidity	0 to 95% rh, non-condensing

**Table 2. NEMA Type 3R Bypass Output Current Ratings (Amps)—Per NEC Motor Tables.**

HP	1	1.5	2	3	5	7.5	10	15	20	25	30	40	50	60	75	100	125
<b>208V</b>	3.9	5.5	7.4	10.4	16.7	22	28	42	54	68	80	104	130	154	–	–	–
<b>240V</b>	3.9	5.5	6.8	9.6	15.2	22	28	42	54	68	80	104	130	154	–	–	–
<b>480V</b>	2.1	3.0	3.4	4.8	7.6	11	14	21	27	34	40	52	65	77	96	124	156

**NOTE:** Drives are current rated devices. Verify that the listed ratings are ≥ the motor full load current rating.

Wiring Diagrams

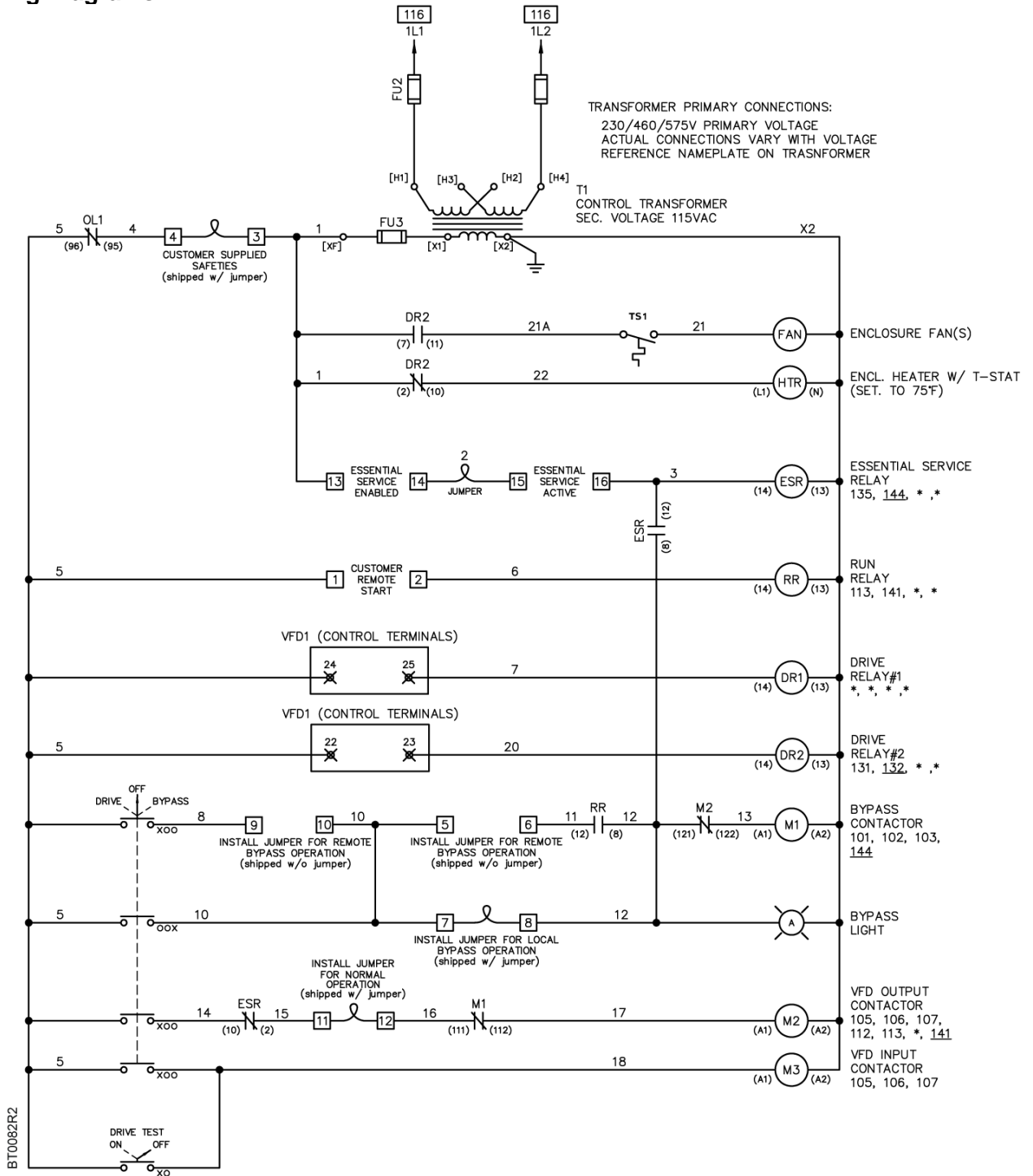

Figure 1. BT300 Type 3R with Bypass, Control Logic Diagram.

Wiring Diagrams, Continued

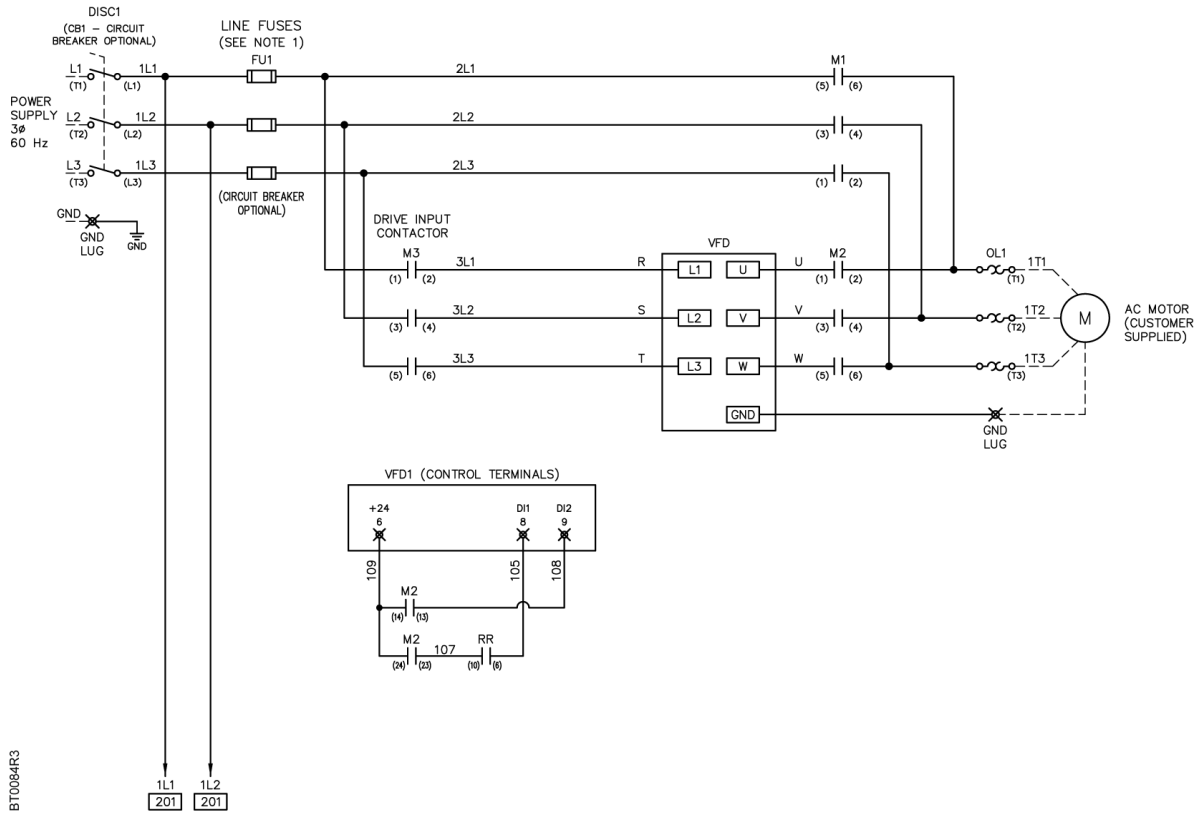

Figure 2. BT300 Type 3R, with Bypass, Power Wiring.

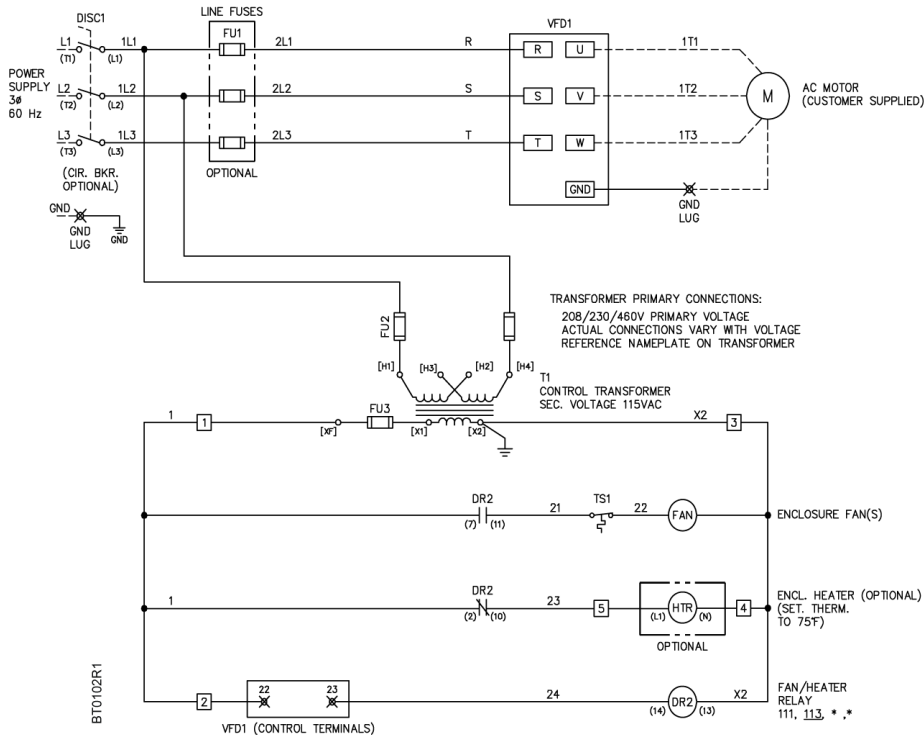
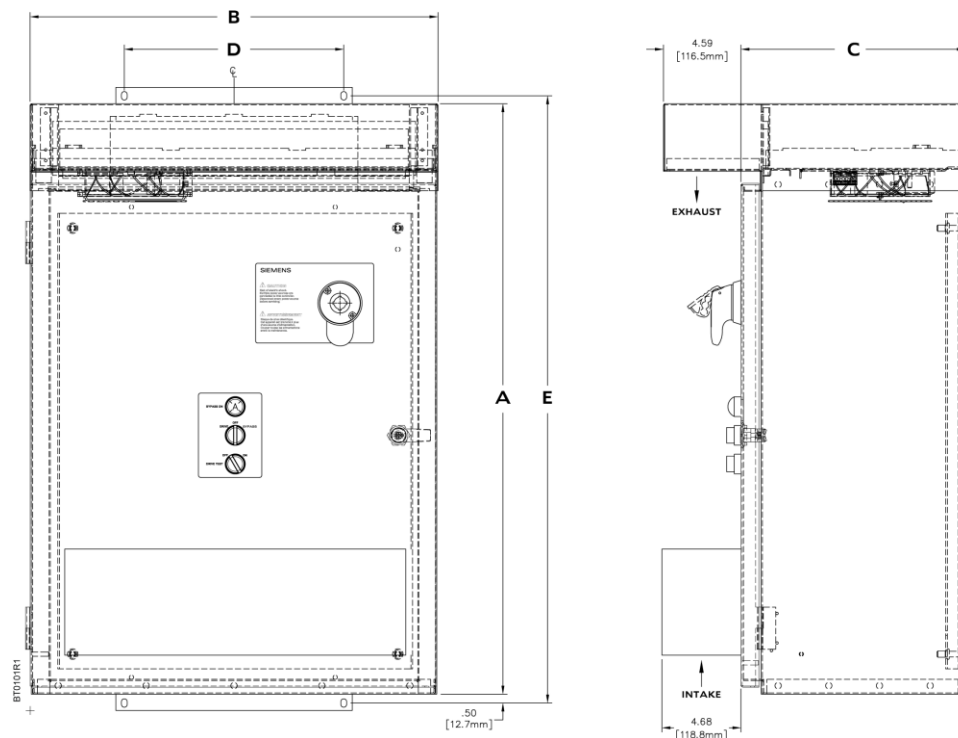

Figure 3. BT300 Type 3R without Bypass, Wiring.

**Dimensions**



**Figure 4. Dimensions (See Error! Reference source not found. and Error! Reference source not found.).**

**Table 3. BT300 Type 3R with Bypass Dimensions.**

HP Range			Dimensions in Inches (mm)					Approx. Weight	
208/230V	480V	VFD Size	A	B	C	D	E	lb	kg
1 – 10	1 – 15	FS4/FS5	35 (889)	24.15 (613)	13.20 (335)	13 (330)	36 (914)	175	79
15 – 20	20 – 40	FS5/FS6	41 (1041)				42 (1067)		
25 - 40	50 – 75	FS7	55 (1397)	36.15 (918)	17.20 (437)	27 (686)	56 (1422)	300	136
50 - 75	100 - 150	FS8	67 (1702)				68 (1727)		

**Table 4. BT300 Type 3R, without Bypass Dimensions.**

HP Range			Dimensions in Inches (mm)					Approx. Weight	
208/230V	480V	VFD Size	A	B	C	D	E	lb	kg
1 – 3	1.5 – 7.5	FS4	29 (737)	24.15 (613)	13.20 (335)	13 (330)	30 (762)	130	59
5 – 10	10 – 20	FS5	35 (889)				36 (914)		
15 - 20	25 – 40	FS6	41 (1041)				42 (1067)		
25 - 40	50 - 75	FS7	55 (1397)	36.15 (918)	17.20 (437)	27 (686)	56 (1422)	250	115
50 – 75	100 – 150	FS8	67 (1702)				68 (1727)		

